

## HSGK high performance screw jacks

# INKOMA - GROUP

INKOMA-GROUP



INKOMA-GROUP Headoffice  
Sitz der INKOMA Maschinenbau GmbH  
Neue Reihe 44  
D - 38162 Schandelah - Germany

phone: +49/(0)5306-9221-0  
fax: +49/(0)5306-9221-50  
e-mail: [info@inkoma.de](mailto:info@inkoma.de)  
internet: [www.INKOMA-GROUP.com](http://www.INKOMA-GROUP.com)

We reserve the right to make technical changes.  
2014-1-MP-OE-e © INKOMA-GROUP



## Product description

### High performance screw jack with cooling fins

INKOMA-screw jacks with oil lubrication and cooling fins add a new dimension to the scope and range of the INKOMA-GROUP screw jacks programme. They guarantee optimum operation even in extreme situations. INKOMA-HSGK screw jacks are extremely robustly designed. Carefully chosen materials and high quality manufacture provide an outstanding drive unit.

The gear housing is in quality grey cast iron. Fixing faces are precisely machined, oil level indicator and ventilation screw are recessed. To achieve optimum heat dissipation the surface area is enhanced by cooling fins orientated with the spindle.

The lifting spindle, whether trapezoidal or ballscrew, is driven by the worm wheel via hardened and ground gears having optimal geometry. Needle rollers rather than plain bushes support the radial loads on the lifting spindle.

These features ensure an increase in life and performance over conventional designs. Input speeds of up to 3000 1/min are possible and both compressive and tensile loads up to 1000 kN can be carried.

The INKOMA-HSGK screw jack can, of course, also be equipped with a wide range of suitable accessories from our range.

If you have questions or problems in respect of our product; e.g. loading, special designs, rust free execution, or modified housing please contact us and take advantage of our experience in jacking systems design.

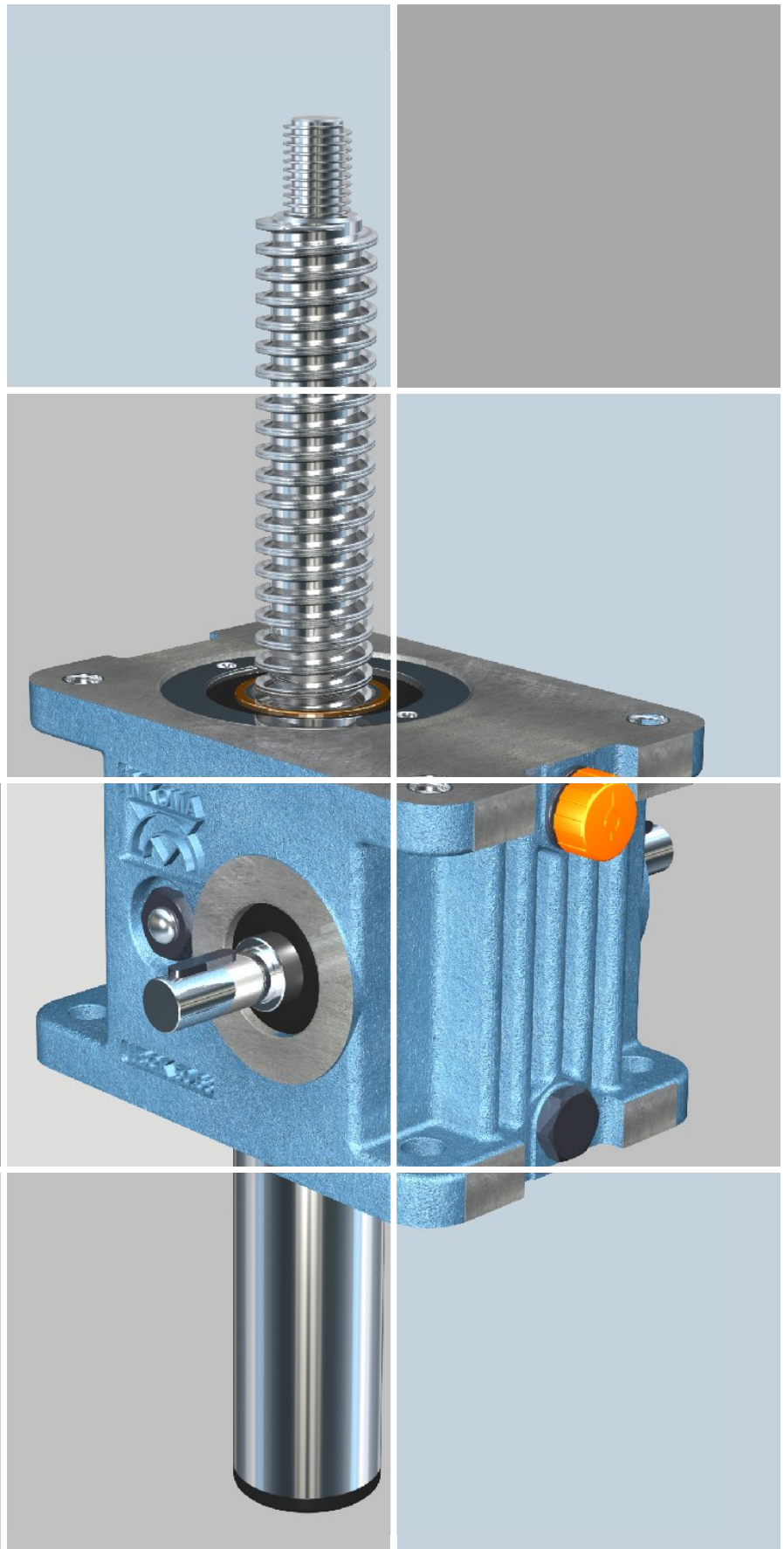

# HSGK high performance screw jacks

## Accessories for rotating spindle version R

### Page references

The comprehensive range of accessories for high capacity screw jacks type HSGK allows the designer the flexibility to tailor the use of the screw jack precisely to the application. All accessories are manufactured to the same exacting standards as the rest of the INKOMA product range.

In addition to this comprehensive selection, customers special requirements can be accommodated.

Please consult our engineering staff.

**Duplex nut - DFM**  
connection of two bellows adaption for lubrication  
see page 194

**Automatic lubrication device**  
allows continuous grease supply  
see page 200

**Safety nut - SFM**  
allows wear monitoring  
see page 194

**Spiral protective sleeve - SF**  
provide spindle protection  
see page 220

**Cardan shafts - GX/GE**  
provide torsionally stiff resilient connections  
see page 222

**Support bearings - SNH**  
to support extended cardan shafts  
see page 224

**Shaft cover - WA**  
covers the exposed spindle end  
see page 212

**Trunnion adaptor - KA/KAS**  
allows articulating fitting of flanged nut  
see page 212

**Bearing block/ flange - LB/LF**  
base mounting bearing unit for KA, KAS or SL  
see page 214

**Motor adaptor - MG**  
for positive and efficient mounting of motors  
see page 232

**Elaflex coupling - EFK**  
flexible shaft coupling  
see page 224

**Bearing plate - GL**  
to support the free end of the spindle  
see page 198

**Flanged nut - FMS/FM**  
for standard applications  
see page 192

**Flange nut with flats - FMF**  
for easy mounting of the screw jacks  
see page 196

**Self aligning nut flange - SL**  
allows articulating fitting  
see page 200

**Self-aligning travelling nut - FMZ**  
for pivot mounting of the screw jacks  
see page 198

**Heavy duty folding bellows - SB**  
provide spindle protection  
see page 218

**3 phase motor**  
flange or foot mounting  
see page 234 - 237

**Handwheel - HR**  
for manual actuation  
of the screw jack  
see page 214

**Gear coupling - M**  
standard or light duty version  
see page 226

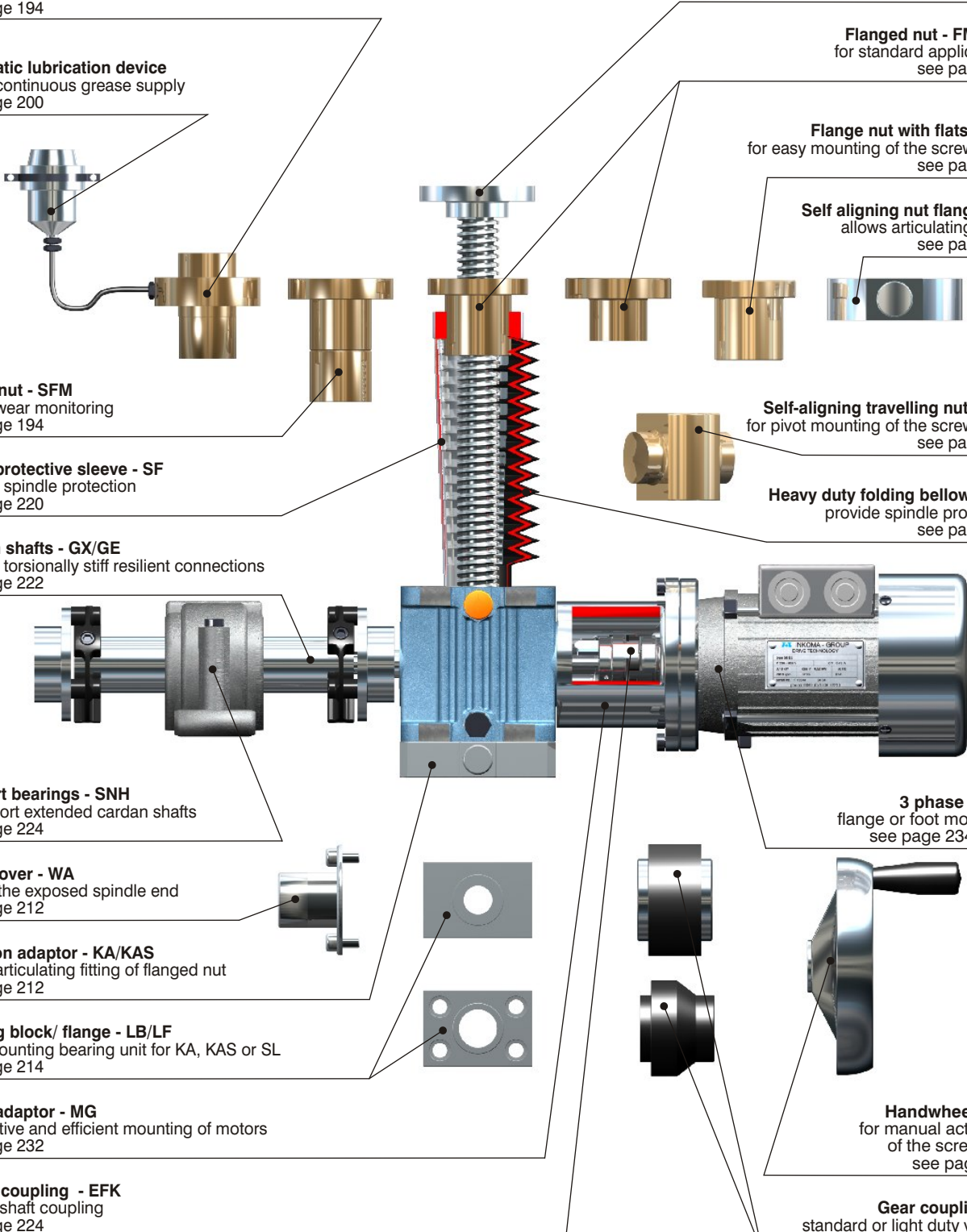



# HSGK high performance screw jacks

## Accessories for translating spindle versions S, SA, SVA

### Page references

**Rod end bearing - GSK**  
for simple attachment  
of the spindle end  
see page 202

**Clevis - GK**  
for simple attachment  
of the spindle end  
see page 204

**Clevis attachment - SE**  
for flexible connection to  
the moving component  
see page 204



**Shaft cover - WA**  
covers the exposed spindle end  
see page 212

**Cardan shafts - GX/GE**  
provide torsionally stiff resilient connections  
see page 222

**Support bearings - SNH**  
to support extended cardan shafts  
see page 224

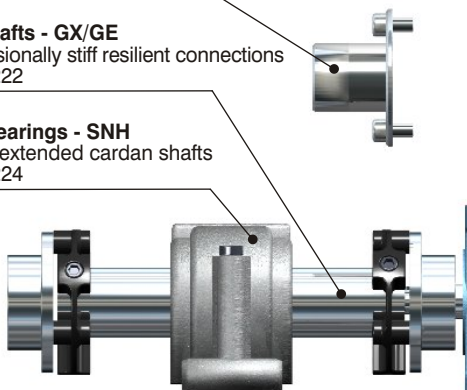

**Trunnion adaptor - KA/KAS**  
allows articulating fitting of flanged nut  
see page 212

**Bearing block - LB**  
base mounting bearing unit for KA or KAS  
see page 214

**Bearing flange - LF**  
base mounting bearing unit for KA or KAS  
see page 214

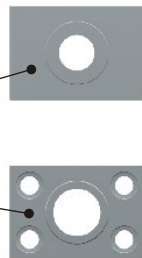

**Setting ring and limit switch with roller follower**  
for monitoring of the spindle position  
see page 208

**Setting ring and inductive proximity switch**  
for monitoring of the spindle position  
see page 208

**Safety nut - SFM-S**  
allows wear monitoring  
see page 206

**Mounting flange - BF**  
for simple attachment  
of the spindle end  
see page 202

**Spiral protective sleeve - SF**  
provide spindle protection  
see page 220

**Heavy duty folding bellows - SB**  
provide spindle protection  
see page 218

**Gear coupling - M**  
standard or light duty version  
see page 226

**Elaflex coupling - EFK**  
flexible shaft coupling  
see page 224

**Motor adaptor - MG**  
for positive and efficient  
mounting of motors  
see page 232

**3 phase motor**  
flange or foot mounting  
see page 234 - 237



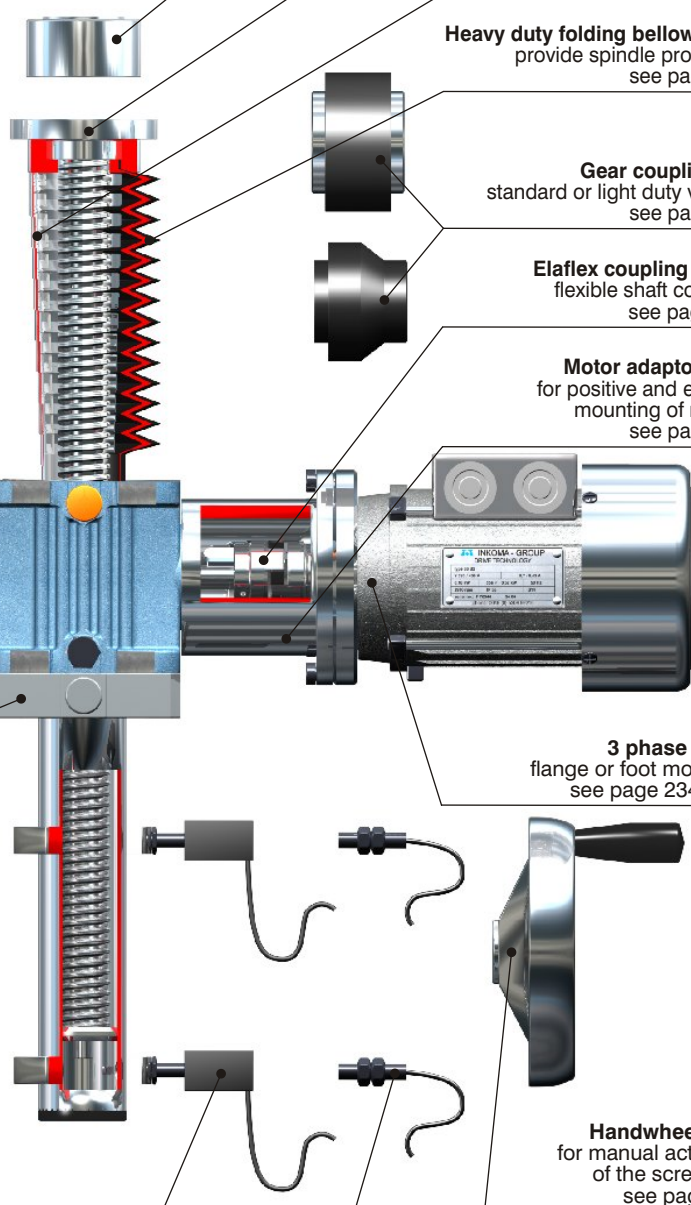





**Handwheel - HR**  
for manual actuation  
of the screw jack  
see page 214

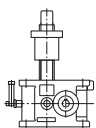

# HSGK high performance screw jacks

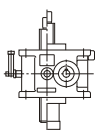
## Contents list

### HSGK high performance screw jacks with rotating and translating spindles

		<b>Technical information</b>	page
		versions cover versions	161
		<b>Dimensions HSGK-3 to HSGK-9</b>	page
		trapezoidal spindle rotating version (R)	162 - 163
		<b>Dimensions HSGK-3 to HSGK-9</b>	page
		trapezoidal spindle translating version (S, SA, SVA)	164 - 165
		<b>Installation attitude for HSGK</b>	page
			166

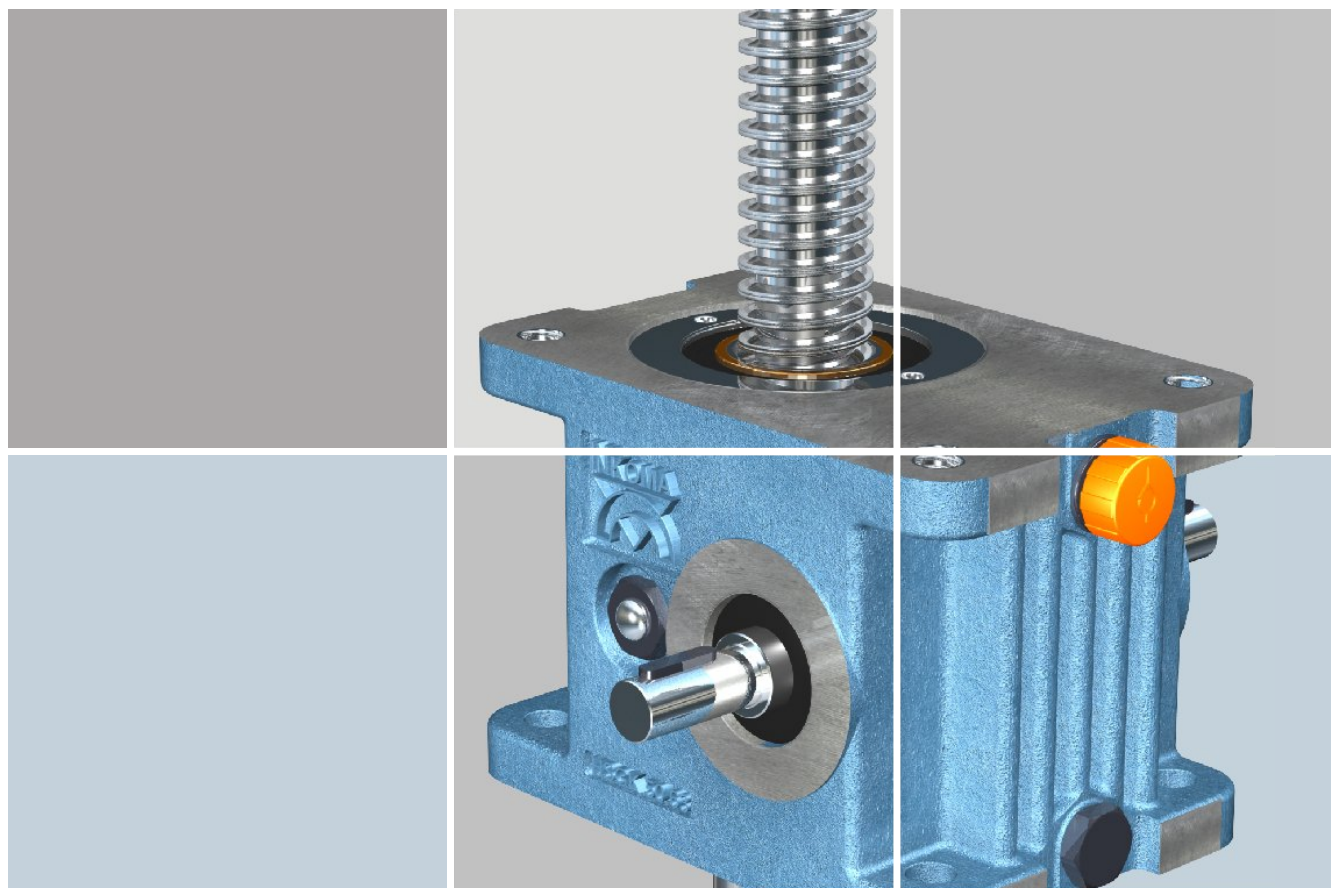

# HSGK high performance screw jacks

## Technical information

### Versions



#### Rotating version (R)

The rotating version (R) achieves linear lifting motion through the rotation of the spindle. In this version the spindle is axially fixed in the gearbox.

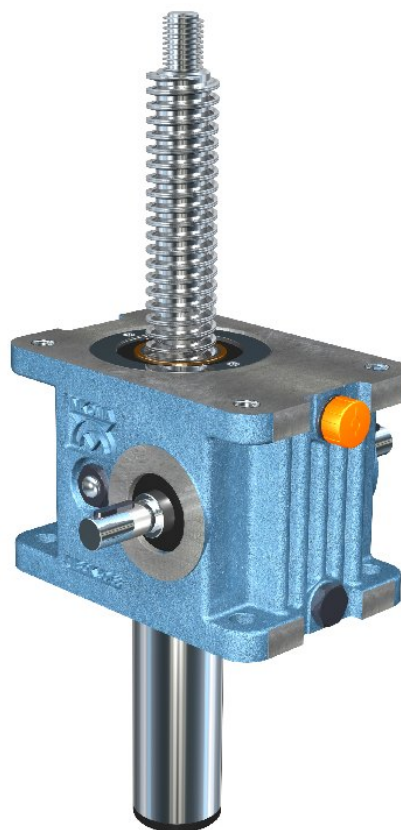

#### Translating version (S)

The translating version (S) lifts the load using the axial movement of the spindle. The spindle is moved through the Jack Housing by the rotation of the worm wheel. Any tendency of the spindle to rotate must be prevented. The spindle is contained within the housing by a travel limiting stop (version SA). Rotation prevention and travel limitation can be combined in version SVA.

### Cover versions

#### K = standard-flat

when no spigot or bellows attachment is required (translating spindle version)

#### H = spigot cover

for bellows attachment

#### HF = spigot cover with guidance ring

in translating spindle version for additional spindle support

#### HS = spigot cover with protective sleeve

extended spigot (H) for spindle cover tube, without guide ring (F)

#### HFS = spigot cover with guidance ring and protective sleeve

extended spigot (H) for spindle cover tube, with guide ring (F)

#### HFV = spigot cover with guidance ring and rotation prevention

extended spigot (H) for square spindle cover tube, with guide ring (F)



# HSGK high performance screw jacks

## Dimensions HSGK-3 to HSGK-9

### Trapezoidal spindle - rotating version (R)

All versions (standard with shafts on sides A and B) are available with a single shaft on side A or B.

#### Versions:

**R:** Rotating spindle

**Lubrication:** Oil

**Lifting force:** 25 to 1000 kN

**Material:** Spheroidal graphite cast iron GGG 40 / AI

**Ratio:** N: normal; L: slow

**Accessories:** see category "Accessories" page 185 - 238

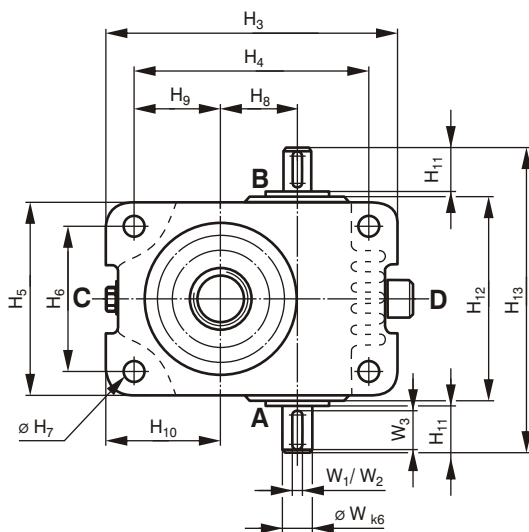
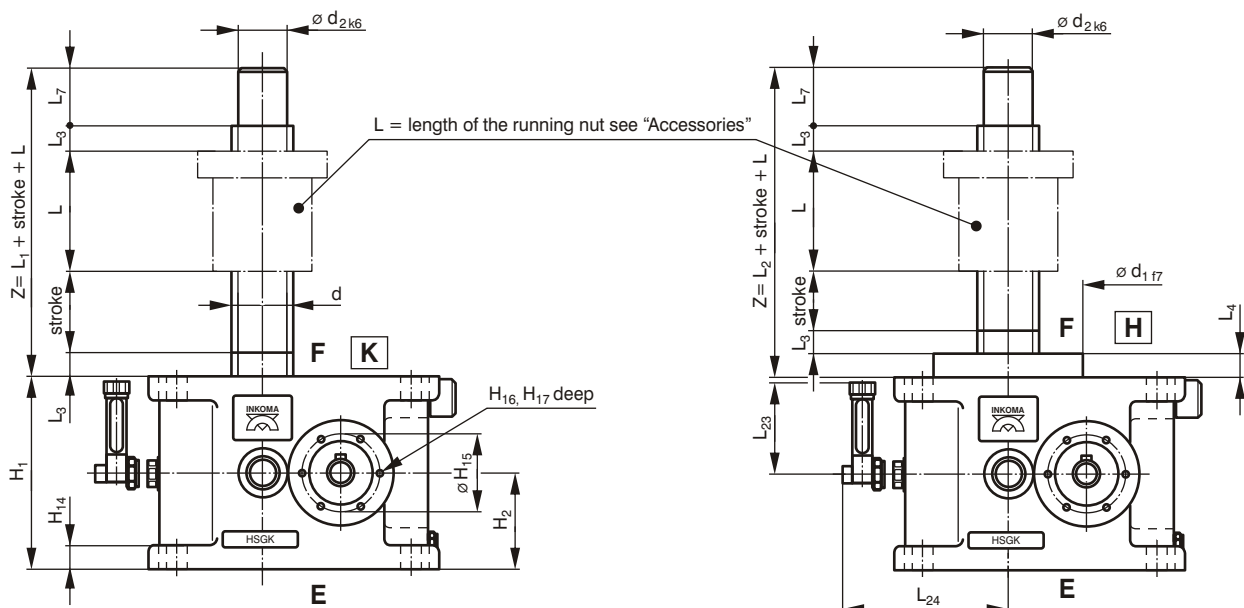

#### Cover version:

**K** = standard-flat

**H** = spigot cover

Version	Cover version spindle side	
R: Rotating spindle	K, H	

# HSGK high performance screw jacks

Order code	Size	max. lifting force [kN]	max. tensile force [kN]	Ratio N / L i	Lift per revolution N / L [mm]	max. input power <sup>2)</sup>		Spindle torque at max. lifting force M <sub>sp.</sub> [Nm]	max. permitted torque at the input shaft M <sub>in.</sub> [Nm]	Housing material	Weight without spindle or protective tube [kg]	Spindle weight per 100 mm [kg]	Amount of gearbox lubricant [kg]	Oil sight glass	Oil level indicator
						P <sub>in.3)</sub> [kW]	P <sub>in.4)</sub> [kW]								
HSGK-3-R-stroke-N/L	3 (25.50)	25	25	6:1 / 24:1	1,33 / 0,33	1,5	2,6	80	48,7	GGG 40	13	0,82	0,4	●	—
HSGK-4-R-stroke-N/L	4 (50.63)	50	50	7:1 / 28:1	1,28 / 0,32	2,3	4,0	190	168	GGG 40	25	1,3	0,7	●	—
HSGK-5-R-stroke-N/L	5 (100.80)	100	100	8:1 / 32:1	1,5 / 0,375	3,6	6,3	478	398	GGG 40	47	1,79	1,4	●	○
HSGK-6-R-stroke-N/L	6 (200.100)	200	178	8:1 / 32:1	1,5 / 0,375	4,8	8,4	1060	705	GGG 40	74	2,52	1,6	●	○
HSGK-7-R-stroke-N/L <sup>1)</sup>	7 (350.125)	350	350	10,66:1 / 32:1	1,5 / 0,5	7,7	13,5	2600	975	GGG 40	145	5,2	5,0	●	○
HSGK-8-R-stroke-N/L <sup>1)</sup>	8 (500.140)	500	500	10,66:1 / 32:1	1,5 / 0,5	10,2	17,9	4235	1640	GGG 40	335	7,7	10,0	●	○
HSGK-9-R-stroke-N/L <sup>1)</sup>	9 (1000.200)	1000	1000	13,33:1 / 40:1	1,5 / 0,5	17,9	31	11115	4260	GGG 40	870	13,82	15,5	●	○

Order code	Dimensions [mm]														
	d Spindle <sup>5)</sup>	d <sub>1</sub>	d <sub>2</sub>	H <sub>1</sub>	H <sub>2</sub>	H <sub>3</sub>	H <sub>4</sub>	H <sub>5</sub>	H <sub>6</sub>	H <sub>7</sub>	H <sub>8</sub>	H <sub>9</sub>	H <sub>10</sub>	H <sub>11</sub>	H <sub>12</sub>
HSGK-3-R-stroke-N/L	Tr 40x8	92	30	130	65	175	140	130	100	13	50	50	67,5	28	133
HSGK-4-R-stroke-N/L	Tr 50x9	122	40	160	80	235	190	160	120	17	63	70	92,5	36	163
HSGK-5-R-stroke-N/L	Tr 60x12	152	40	200	100	275	220	200	150	21	80	75	102,5	58	204
HSGK-6-R-stroke-N/L	Tr 70x12	182	50	230	115	330	270	230	175	28	100	87,5	117,5	58	235
HSGK-7-R-stroke-N/L <sup>1)</sup>	Tr 100x16	222	80	300	150	410	330	300	230	39	125	110	150	82	305
HSGK-8-R-stroke-N/L <sup>1)</sup>	Tr 120x16	262	95	350	175	490	390	350	260	46	140	130	180	82	355
HSGK-9-R-stroke-N/L <sup>1)</sup>	Tr 160x20	352	130	450	225	680	550	460	330	66	200	185	250	105	470

Order code	Dimensions [mm]															
	H <sub>13</sub>	H <sub>14</sub>	H <sub>15</sub>	H <sub>16</sub>	H <sub>17</sub>	L <sub>1</sub>	L <sub>2</sub>	L <sub>3</sub>	L <sub>4</sub>	L <sub>7</sub>	L <sub>23</sub>	L <sub>24</sub>	W	W <sub>1</sub>	W <sub>2</sub>	W <sub>3</sub>
HSGK-3-R-stroke-N/L	192	15	50	6xM6	12	79	97	20	18	39	-	-	16	5	5	25
HSGK-4-R-stroke-N/L	238	20	70	6xM6	14	89	109	20	20	49	-	-	24	8	7	32
HSGK-5-R-stroke-N/L	322	25	85	6xM8	16	89	114	20	25	49	80	130	32	10	8	50
HSGK-6-R-stroke-N/L	356	28	110	6xM10	20	94	124	20	30	54	100	150	38	10	8	50
HSGK-7-R-stroke-N/L <sup>1)</sup>	474	35	-	-	-	119	154	20	35	79	125	180	42	12	8	70
HSGK-8-R-stroke-N/L <sup>1)</sup>	524	45	-	-	-	139	179	20	40	99	150	210	50	14	9	70
HSGK-9-R-stroke-N/L <sup>1)</sup>	682	60	-	-	-	159	209	20	50	119	200	280	70	20	12	100

<sup>1)</sup> Please ask about availability.

<sup>2)</sup> Max. permitted values for rotating trapezoidal spindles.

The translating type or units with ball screws allow higher values.

<sup>3)</sup> At 20°C environmental temperature and 20% ED duty factor/ hour.

<sup>4)</sup> At 20°C environmental temperature and 10% ED duty factor/ hour.

<sup>5)</sup> Also available with ball screw.

● - standard (0)

○ - option (1)

— - not possible

## Ordering example:

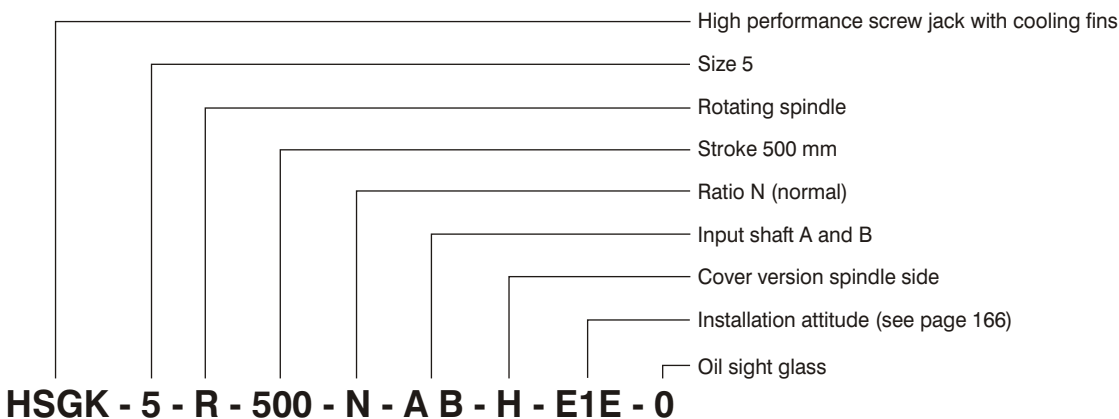



# HSGK high performance screw jacks

## Dimensions HSGK-3 to HSGK-9

### Trapezoidal spindle - translating version (S, SA, SVA)

All versions (standard with shafts on sides A and B) are available with a single shaft on side A or B.

**Versions:**

**S:** Translating spindle

**SA:** Translating spindle with travel limiter

**SVA:** Translating spindle with rotation prevention and travel limiter

**Lifting force:** 25 to 1000 kN

**Ratio:** N: normal; L: slow

**Lubrication:** Oil

**Material:** Spheroidal graphite cast iron GGG 40/Al

**Accessories:** see category "Accessories" page 185 - 238

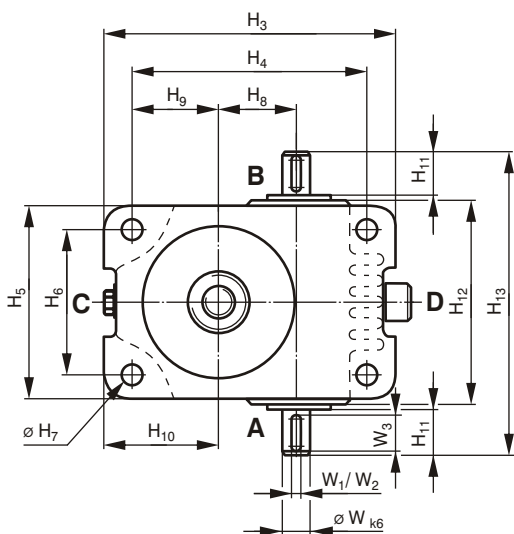
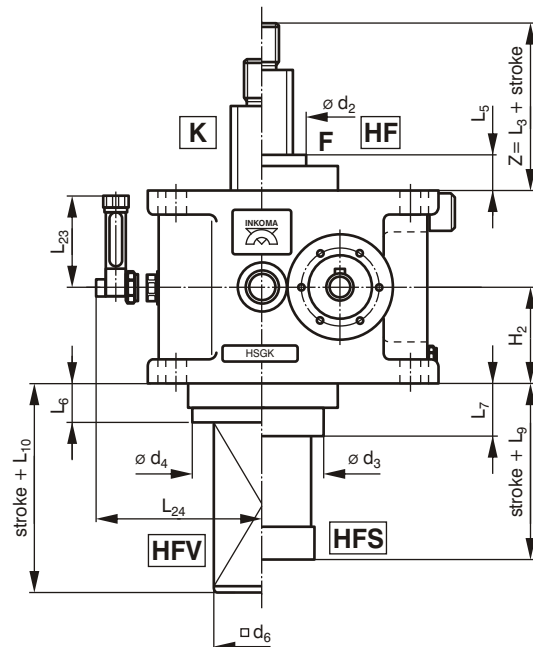
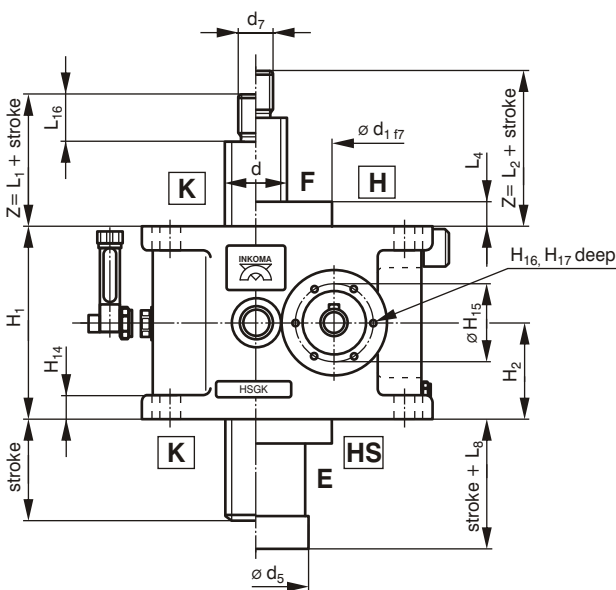

**Cover version:**

- K** = standard-flat
- H** = spigot cover
- HF** = spigot cover with guidance ring
- HS** = spigot cover with protective sleeve
- HFS** = spigot cover with guidance ring and protective sleeve
- HFV** = spigot cover with guidance ring and rotation prevention

Version	Cover version spindle side	Cover version protection sleeve side
<b>S:</b> Translating spindle	K, H, HF	K, HS, HFS
<b>SA:</b> Translating spindle with travel limiter	K, H, HF	HS, HFS
<b>SVA:</b> Translating spindle with rotation prevention and travel limiter	K, H, HF	HFV

# HSGK high performance screw jacks

Order code	Size	max. lifting force [kN]	max. tensile force [kN]	Ratio N / L i	Lift per revolution N / L [mm]	max. input power <sup>2)</sup>		Spindle torque at max. lifting force M <sub>sp</sub> [Nm]	max. permitted torque at the input shaft M <sub>in</sub> [Nm]	Housing material	Weight without spindle or protective tube [kg]	Spindle weight per 100 mm [kg]	Amount of gearbox lubricant [kg]	Oil sight glass	Oil level indicator
						P <sub>in.3)</sub> [kW]	P <sub>in.4)</sub> [kW]								
HSGK-3-S-stroke-N/L	3 (25.50)	25	25	6:1 / 24:1	1,33 / 0,33	1,5	2,6	80	48,7	GGG 40	13	0,82	0,4	●	—
HSGK-4-S-stroke-N/L	4 (50.63)	50	50	7:1 / 28:1	1,28 / 0,32	2,3	4,0	190	168	GGG 40	25	1,3	0,7	●	—
HSGK-5-S-stroke-N/L	5 (100.80)	100	100	8:1 / 32:1	1,5 / 0,375	3,6	6,3	478	398	GGG 40	47	1,79	1,4	●	○
HSGK-6-S-stroke-N/L	6 (200.100)	200	178	8:1 / 32:1	1,5 / 0,375	4,8	8,4	1060	705	GGG 40	74	2,52	1,6	●	○
HSGK-7-S-stroke-N/L <sup>1)</sup>	7 (350.125)	350	350	10,66:1 / 32:1	1,5 / 0,5	7,7	13,5	2600	975	GGG 40	145	5,2	5,0	●	○
HSGK-8-S-stroke-N/L <sup>1)</sup>	8 (500.140)	500	500	10,66:1 / 32:1	1,5 / 0,5	10,2	17,9	4235	1640	GGG 40	335	7,7	10,0	●	○
HSGK-9-S-stroke-N/L <sup>1)</sup>	9 (1000.200)	1000	1000	13,33:1 / 40:1	1,5 / 0,5	17,9	31	11115	4260	GGG 40	870	13,82	15,5	●	○

Order code	Dimensions [mm]																				
	d Spindle <sup>5)</sup>	d <sub>1</sub>	d <sub>2</sub>	d <sub>3</sub>	d <sub>4</sub>	d <sub>5</sub>	d <sub>6</sub>	d <sub>7</sub>	H <sub>1</sub>	H <sub>2</sub>	H <sub>3</sub>	H <sub>4</sub>	H <sub>5</sub>	H <sub>6</sub>	H <sub>7</sub>	H <sub>8</sub>	H <sub>9</sub>	H <sub>10</sub>	H <sub>11</sub>	H <sub>12</sub>	H <sub>13</sub>
HSGK-3-S-stroke-N/L	Tr 40x8	92	60	80	100	70	70	M20x1,5	130	65	175	140	130	100	13	50	50	67,5	28	133	192
HSGK-4-S-stroke-N/L	Tr 50x9	122	70	100	115	85	80	M30x2	160	80	235	190	160	120	17	63	70	92,5	36	163	238
HSGK-5-S-stroke-N/L	Tr 60x12	152	100	120	130	90	80	M42x3	200	100	275	220	200	150	21	80	75	102,5	58	204	322
HSGK-6-S-stroke-N/L	Tr 70x12	182	125	150	-	95	100	M56x3	230	115	330	270	230	175	28	100	87,5	117,5	58	235	356
HSGK-7-S-stroke-N/L <sup>1)</sup>	Tr 100x16	222	160	180	200	136	140	M80x3	300	150	410	330	300	230	39	125	110	150	82	305	474
HSGK-8-S-stroke-N/L <sup>1)</sup>	Tr 120x16	262	195	220	260	143	180	M100x4	350	175	490	390	350	260	46	140	130	180	82	355	524
HSGK-9-S-stroke-N/L <sup>1)</sup>	Tr 160x20	352	240	290	310	198	220	M140x4	450	225	680	550	460	330	66	200	185	250	105	470	682

Order code	Dimensions [mm]																						
	H <sub>14</sub>	H <sub>15</sub>	H <sub>16</sub>	H <sub>17</sub>	L <sub>1</sub>	L <sub>2</sub>	L <sub>3</sub>	L <sub>4</sub>	L <sub>5</sub>	L <sub>6</sub>	L <sub>7</sub>	L <sub>8</sub> S	L <sub>8</sub> SA	L <sub>9</sub> S	L <sub>9</sub> SA	L <sub>10</sub> SVA	L <sub>16</sub>	L <sub>23</sub>	L <sub>24</sub>	W	W <sub>1</sub>	W <sub>2</sub>	W <sub>3</sub>
HSGK-3-S-stroke-N/L	15	50	6xM6	12	50	68	76	18	26	28	39	22	34	46	68	107	29	-	-	16	5	5	25
HSGK-4-S-stroke-N/L	20	70	6xM6	14	60	80	89	20	29	33	44	22	34	52	70	123	39	-	-	24	8	7	32
HSGK-5-S-stroke-N/L	25	85	6xM8	16	70	95	109	25	39	40	54	22	68	61	100	136	49	80	130	32	10	8	50
HSGK-6-S-stroke-N/L	28	110	6xM10	20	75	105	124	30	49	-	64	22	75	71	117	152	54	100	150	38	10	8	50
HSGK-7-S-stroke-N/L <sup>1)</sup>	35	-	-	-	100	135	154	35	54	54	74	22	85	76	130	154	79	125	180	42	12	8	70
HSGK-8-S-stroke-N/L <sup>1)</sup>	45	-	-	-	120	160	184	40	64	63	84	22	95	86	140	179	99	150	210	50	14	9	70
HSGK-9-S-stroke-N/L <sup>1)</sup>	60	-	-	-	140	190	219	50	79	73	109	22	105	101	160	199	119	200	280	70	20	12	100

<sup>1)</sup> Please ask about availability.

<sup>2)</sup> Max. permitted values for rotating trapezoidal spindles.

The translating type or units with ball screws allow higher values.

<sup>3)</sup> At 20°C environmental temperature and 20% ED duty factor/ hour.

<sup>4)</sup> At 20°C environmental temperature and 10% ED duty factor/ hour.

<sup>5)</sup> Also available with ball screw.

● - standard (0)

○ - option (1)

— - not possible

## Ordering example:

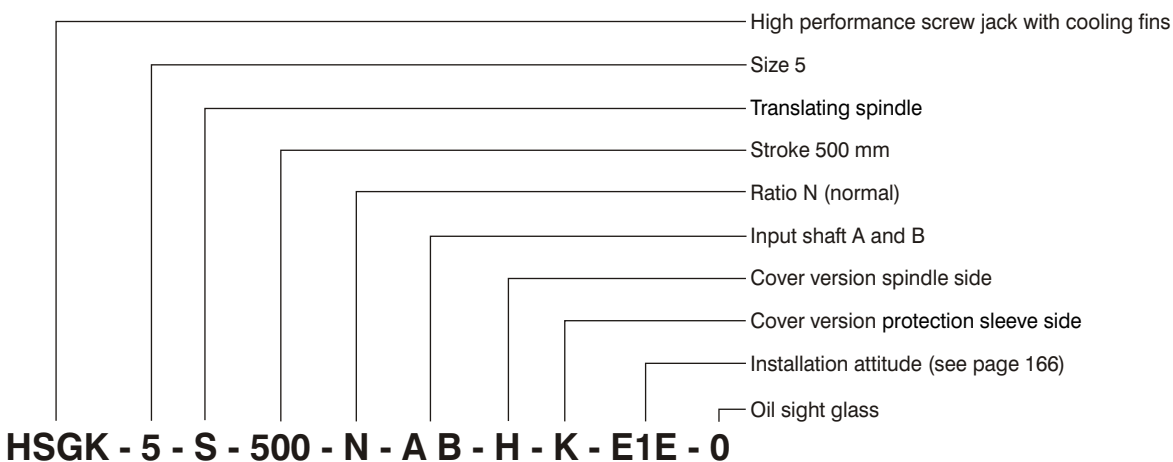

# HSGK high performance screw jacks

## Installation attitude for HSGK

Trapezoidal spindle - rotating and translating versions (R, S, SA, SVA)

Fixing surface: E

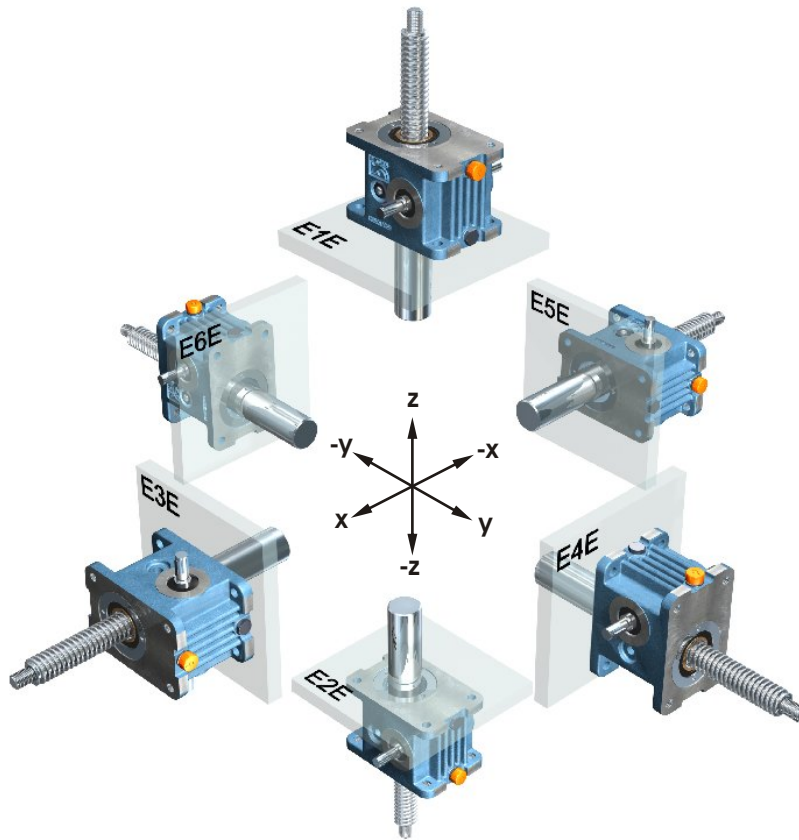

Fixing surface: F

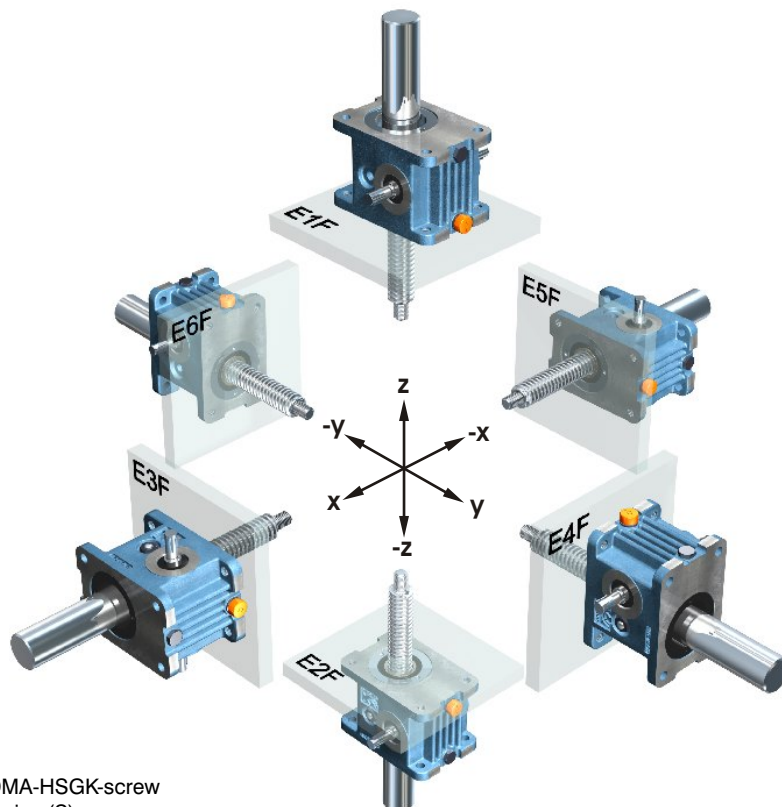

This view shows the INKOMA-HSGK-screw jack in translating spindle version (S).